

ROLLERCO

Window & Door Spare Parts

<u>Rollerco Number</u> 1-2510	<u>Part Name</u> MTM Door Roller & Carriage
---	---

Description
Plastic carriage body & roller suit MTM and Adelaide Windows sliding doors.

Picture

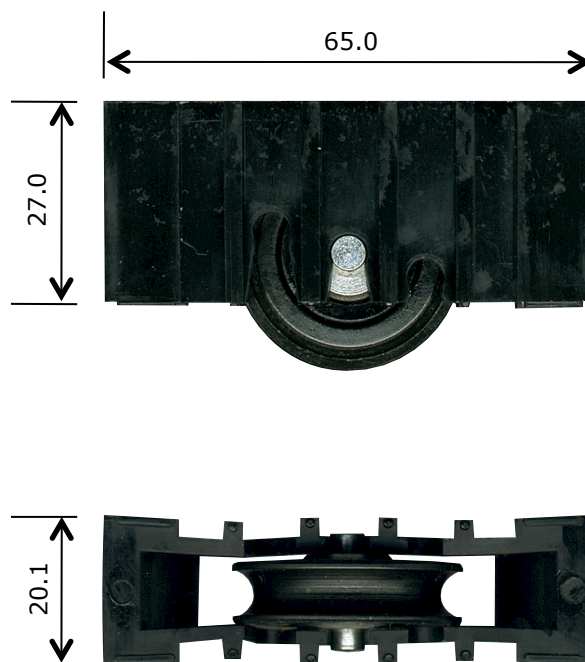

Notes / Comments
Injection moulded 3 step adjustment carriage fitted with nylon tyre bearing roller. Replacement roller is 2-1130.

<u>Unit of Supply</u> Each	<u>Recommended Maximum Load</u> 25kg	<u>Adjustment Range</u> 7mm
--------------------------------------	--	---------------------------------------

ROLLERCO
 3, 26-28 Jacobsen Crescent, Holden Hill, South Australia 5088
 P: 08 8266 2554 F: 08 8266 1522 E: sales@rollerco.com.au