

<u>Rollerco Number</u> 4-1160	<u>Part Name</u> G James Sliding Window Roller
---	--

Description
Sliding window carriage and roller suits G James aluminium sliding windows.

Picture

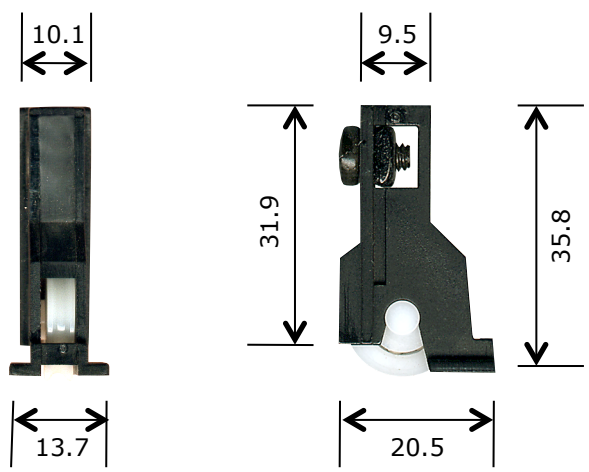

Notes / Comments
Injection moulded plastic carriage fitted with 15.7mm nylon tyre bearing roller and includes phillips head fixing screw & nut.

<u>Unit of Supply</u> Each	<u>Recommended Maximum Load</u> 12kg	<u>Adjustment Range</u> 6mm
--------------------------------------	--	---------------------------------------

ROLLERCO
 3, 26-28 Jacobsen Crescent, Holden Hill, South Australia 5088
 P: 08 8266 2554 F: 08 8266 1522 E: sales@rollerco.com.au