

<u>Rollerco Number</u> 4-1650	<u>Part Name</u> Dowell Window Skid
---	---

Description
Plastic window skid block and carriage to suit old Dowell sliding windows.

Picture

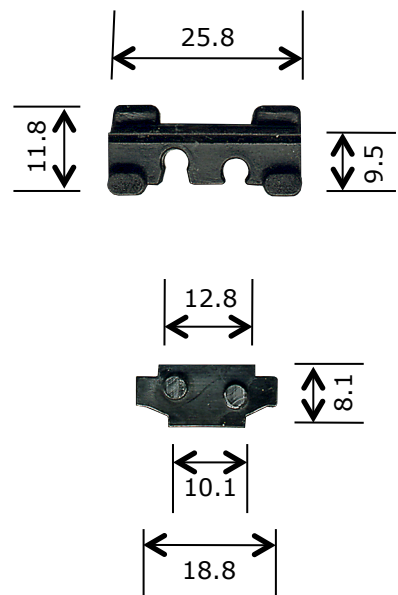

Notes / Comments
Injection moulded outer carriage with adjustable plastic skid block. Rollerco part 4-1030 (roller & axle) will fit into the outer carriage.

<u>Unit of Supply</u> Each	<u>Recommended Maximum Load</u> 10 kg	<u>Adjustment Range</u> 1.5 mm
--------------------------------------	---	--

ROLLERCO
 3, 26-28 Jacobsen Crescent, Holden Hill, South Australia 5088
 P: 08 8266 2554 F: 08 8266 1522 E: sales@rollerco.com.au