

ROLLERCO



Window & Door Spare Parts

Rollerco Number

4-2080

Part Name

Sliding Window Roller

Description

Adjustable sliding window carriage and roller.

Picture

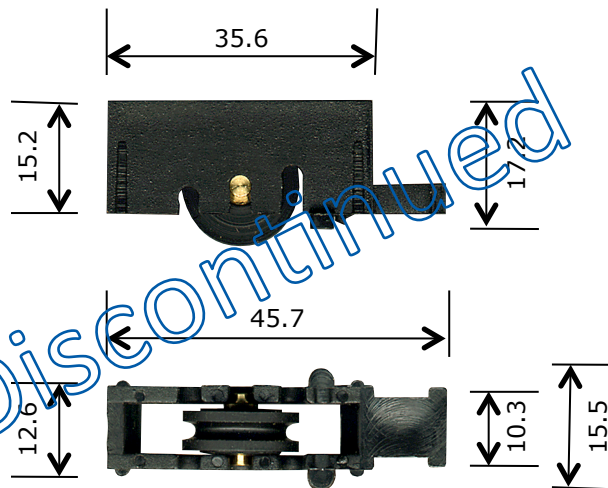

Notes / Comments

Injection moulded plastic 3 stage adjustment carriage fitted with 16mm grooved plastic roller and brass axle. Replacement roller is 4-1630.

Unit of Supply

Each

Recommended Maximum Load

8 kg

Adjustment Range

2.2 mm

ROLLERCO

3, 26-28 Jacobsen Crescent, Holden Hill, South Australia 5088

P: 08 8266 2554 F: 08 8266 1522 E: sales@rollerco.com.au

Reproduction of this document in any part is not allowed without the written consent of Rollerco. Whilst all care has been taken in it's accuracy, Rollerco accept no liability for any errors.