

INSTALLATION INSTRUCTIONS



IMPORTANT INFORMATION

Single cavity units have a door weight limit of 65kg. Double cavity units have a door weight limit of 45kg each door. Cavity units are not load bearing. When installing double Cavity units it is important that the track is fixed to a structural member. Screw through the centre of track. Only use button head screws (not provided in fittings).

Care should be taken when installing the cavity unit into wall tiled areas. Please consult with the tile manufacturer as to their recommended fixing and tiling methods in accordance with the relevant standards.

Do not remove the temporary Cavity Pocket Spacer Blocks in the opening of the cavity throat until the wall sheeting has been completed.

ITEMS REQUIRED

- 1 x cavity pocket
- 1 x head track assembly
- 2 x removable fillets
- 1 x glide guide kit*
- 1 x trolley kit
- 1 x closing jamb
- 2 x 60mm converter bumper stops

Glide guide kit contents*

- 2 x glide guide strips
- 2 x nylon finger guides
- 2 x 15mm round head screws
- 10 x panel pins

* WA, NSW, QLD only.

Trolley kit contents

- 2 x trolley assemblies
- 2 x door support brackets
- 1 x reversible door guide*
- 1 x spanner
- 1 x spanner clip
- 2 x 16mm pan head screw
- 1 x 15mm countersunk screw
- 4 x 35mm countersunk screws
- 4 x 30mm hex head screws
- 1 x 25mm concrete nail
- 4 x complete snap caps
- 8 x 18mm metal thread button head screws
- 3 x 65mm metal thread hex head screws

INSTALLATION INSTRUCTIONS

PLATINUM 4000 CAVITY ELEVATION

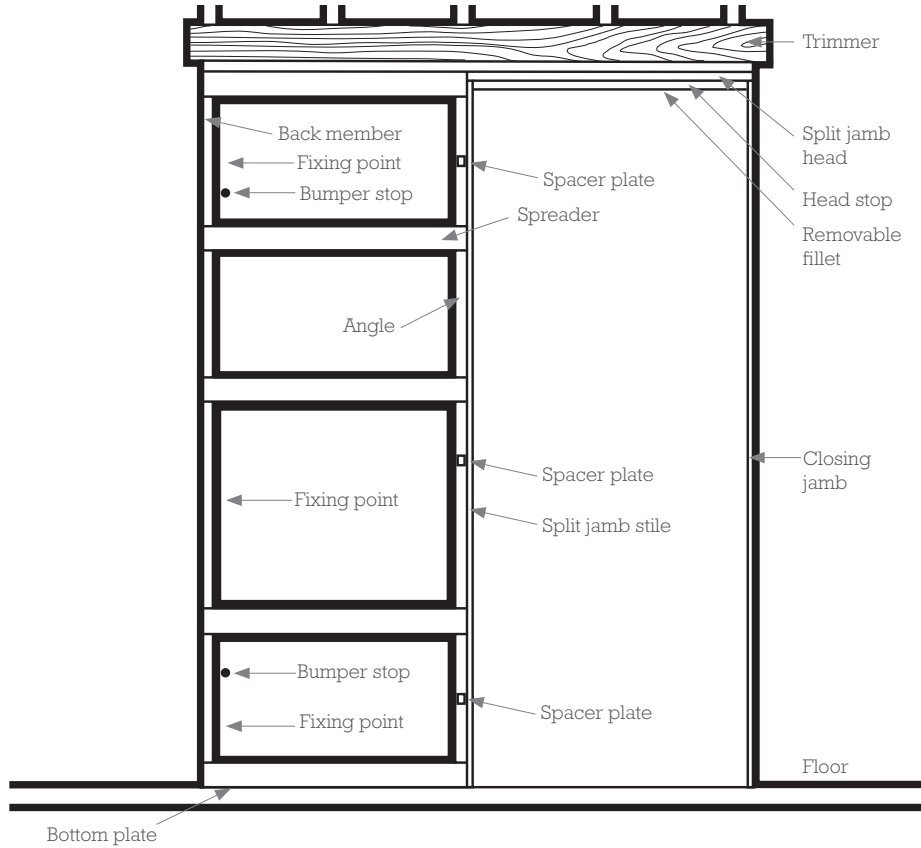

FLUSH JAMB AND FLUSH PULL INSTALLATION OPTIONS

To convert a flush jamb cavity unit into a flush pull unit install the 2 x 60mm converter bumper stops (included in the fittings) onto the back member as close as possible to the existing bumper stops. Some unit sizes/types may not be available in all states.

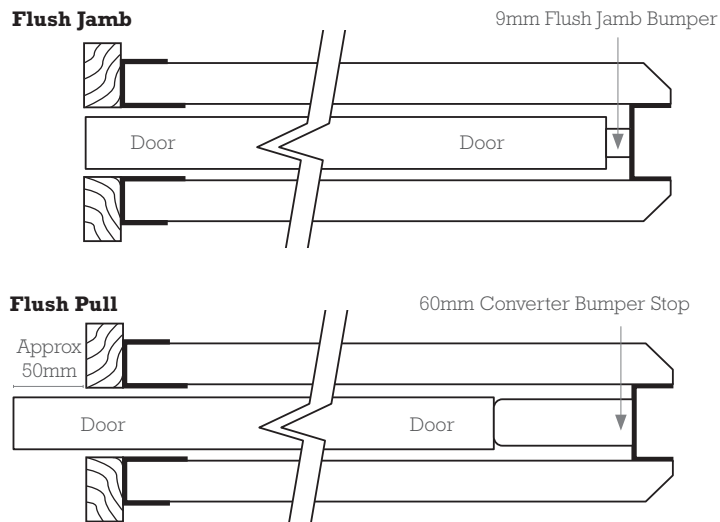

Cavity unit depicted with door in the fully open position.

INSTALLATION INSTRUCTIONS

STEP 1

Fit and screw the head track assembly to the cavity pocket using the 8 x 18mm metal thread button head screws. **Do not remove the temporary spacer blocks in the opening of the cavity throat until the wall sheeting has been completed.**

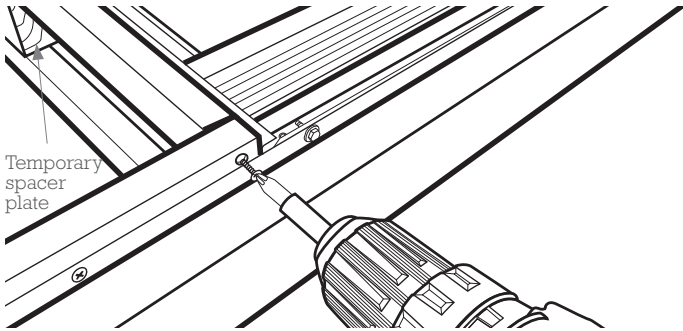

STEP 2

Using a 50mm screw/nail (not provided in fittings) secure the split jamb head to the split jamb stile (ensure this is predrilled prior). Turn the cavity pocket over and repeat Step 2.

STEP 3

The closing stile is a universal stile for all cavities and requires 20mm to be trimmed from the top to fit the Platinum 4000 head section. Screw/nail (not provided with fittings) the closing jamb to the head section fixing through the head track and timber into the closing jamb stile. **Note: If a double door unit is being installed a closing jamb is not supplied. For Double Door installations refer to Step 13 for instructions on how to install the double door stop.**

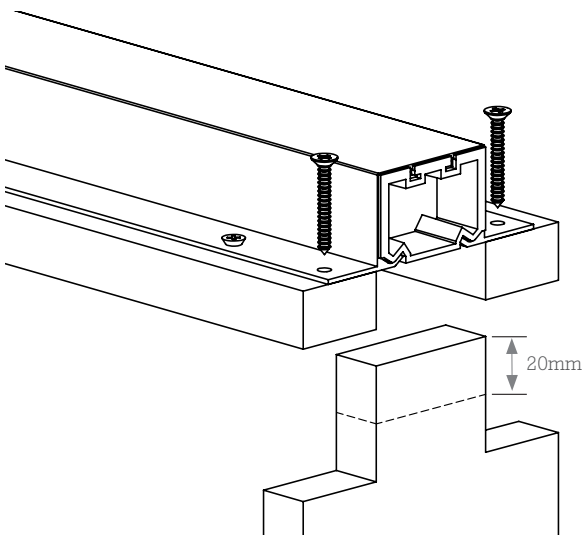

STEP 4

Place the assembled unit in position in the opening. Plumb and fasten to the brick/stud. It is important that the back member of the cavity pocket is installed by packing and fixing as close as possible to the two bumper stops. A minimum of three fixings is required - see Platinum 4000 Cavity Elevation. Use the 3 x 65mm metal thread hex head screws. **Do not remove the temporary spacer blocks in the opening of the cavity throat until the wall sheeting has been completed.** Fasten the base to the floor using the 1 x concrete nail or alternative fixing method.

STEP 5

Note: If installing a Soft Closer Kit refer to the Platinum 4000 Soft Closer Kit installation instructions for step 5.

Place the 2 x carriage assemblies in the track.

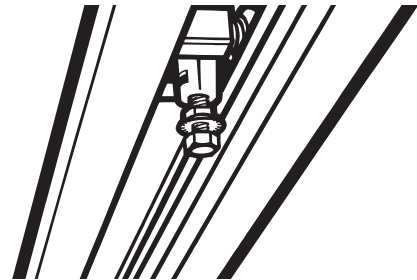

STEP 6

Attach the 2 x door support brackets to the top of the door using the 4 x 30mm hex head screws, 100mm in from each side.

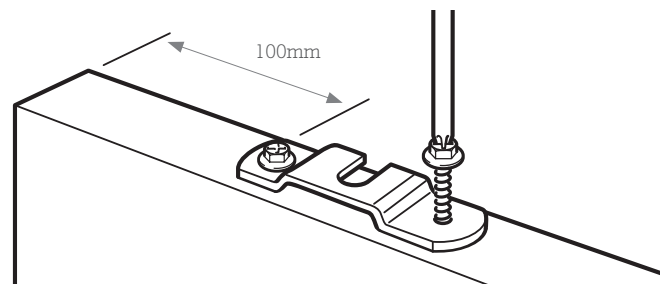

STEP 7

Attach the 1 x spanner storage clip to the top of the door using the 1 x 15mm countersunk screw.

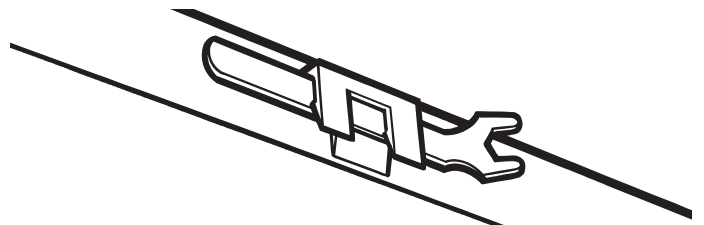

INSTALLATION INSTRUCTIONS

STEP 8 (QLD, NSW, WA only)

Cut the 2 x glide guide strips to suit the door width. Tack both strips to the bottom of the door using 5 x panel pins with each glide guide strip (total 10 x panel pins).

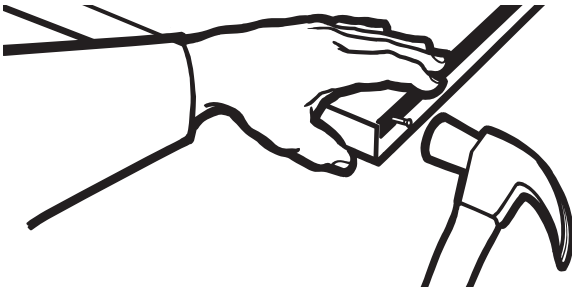

STEP 9

With the door in the opening, lift to locate each door support bracket onto the trolley assembly thread, ensuring the self locking nuts are above the bracket.

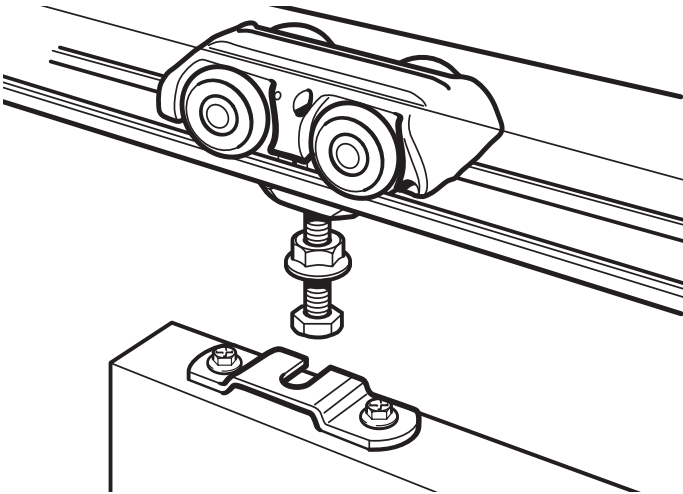

STEP 10

Use the 1 x spanner provided to raise and level the door to the required height and to plumb against the closing jamb. Tighten the lock nuts when the door is correctly positioned. Do not discard the spanner. Attach it to the spanner clip for future use.

STEP 11 (SA, VIC only)

Slide the reversible door guide along the groove in the bottom of the door. Loosely screw the guide to the split jamb using the 2 x 16mm pan head screws. Centre the door in the pocket and then fully tighten screws.

STEP 12

Screw in place the removable fillets using 4 x 35mm countersunk screws through a white snap cap base. Finish off with supplied snap caps. Refer to drawing in step 12 and diagram 12A or 12B depending on your state.

DIAGRAM 12A (SA, VIC only)

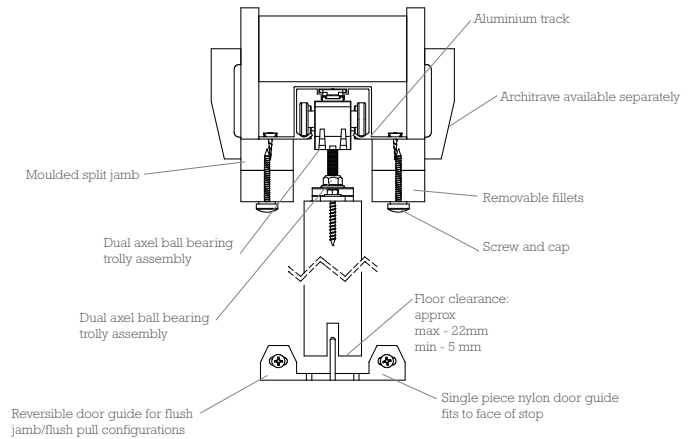
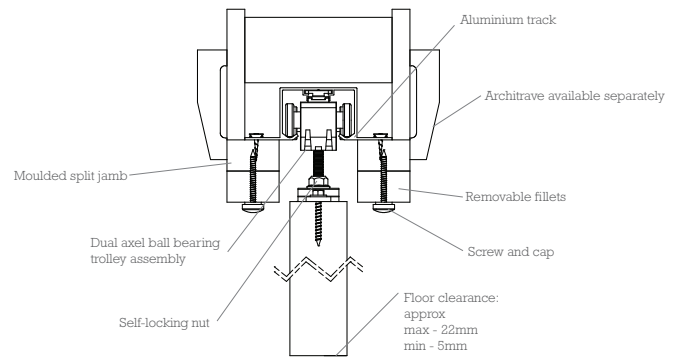
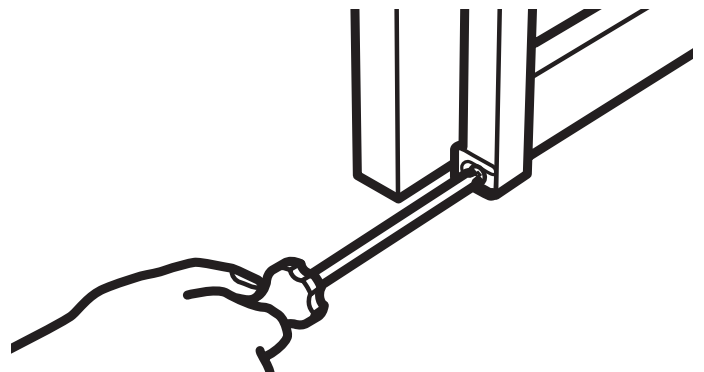

DIAGRAM 12B (QLD, NSW, WA only)



(QLD, NSW, WA only). Fix the two nylon finger guides to the base of the frame using the elongated opening (for subsequent adjustment). The flexible portion protrudes into the cavity. When the guides are positioned correctly, fasten with 2 x 15mm round head screws.



INSTALLATION INSTRUCTIONS

STEP 13 DOUBLE DOOR STOP APPLICATIONS ONLY

ITEMS REQUIRED

1 x Cavity Double Door-Stop Kit

■ 2 x trigger plate

■ 4 x M4x4 grub screws

■ 2 x double doorstop with 25mm CSK screw fitted

1 x Screwdriver (not supplied)

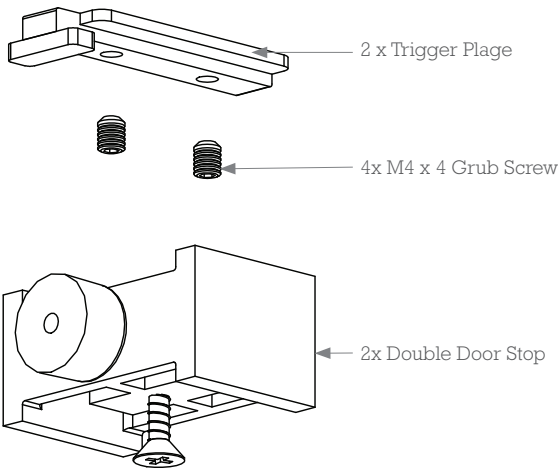

STEP 13A

Mark the centre line of the head track.

STEP 13B

Insert both trigger plates through the slot cut-out and position them approximately 60mm from the centre line of the head track.

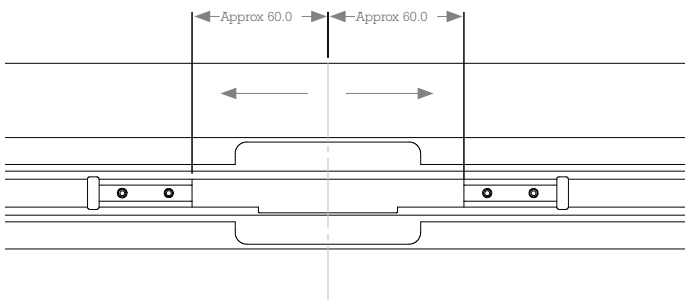

STEP 13C

Insert each doorstop through the slot cut-out and position them approximately 65mm* from the centre line of the track.

***The position of the doorstop is relative to the position of the trolley mount onto the door, this is indicative only.**

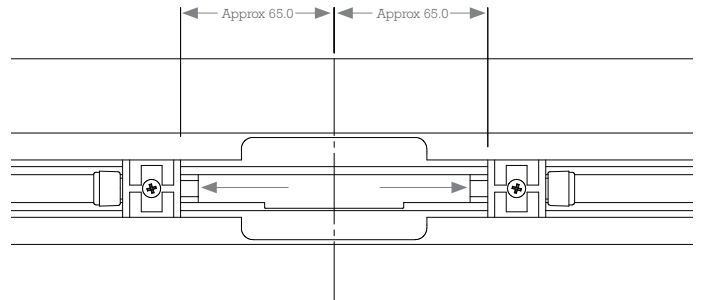

STEP 13D

Adjust the position of the doorstops to ensure double doors meet in the centre and tighten screws to secure.

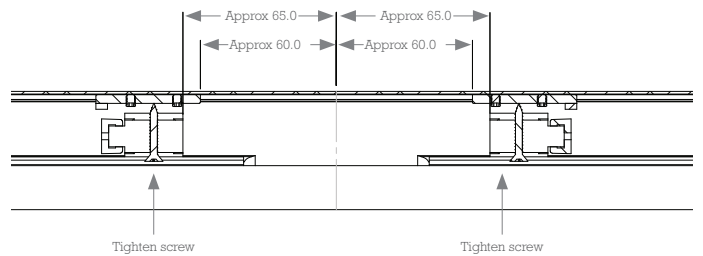

FAILURE TO ADHERE TO INSTALLATION INSTRUCTIONS WILL VOID WARRANTY.
For full Terms and Condition of Warranty visit www.corinthian.com.au/about/warranty

Corinthian Industries (Australia) Pty Limited is a subsidiary of JELD-WEN Australia Pty Limited. Whilst the utmost care is taken to ensure the accuracy of the information contained herein, it is provided in the understanding that the company shall under no circumstances be liable for any injuries, expenses or other losses which may in any way be attributable to the use or adoption of such data and/or design details. All dimensions indicated are nominal only. Corinthian Doors reserves the right to alter or amend without prior notice data and design details specified herein. Photographs or illustrations may not exactly depict the design or specification and may vary to actual. Doors and products are supplied unfinished unless otherwise specified. www.corinthian.com.au Re-Order Code JWCNAT0513/0521. JUN21 JELD0298